

Henry Santos

DESIGN PORTFOLIO



As a persistent learner, maker and teacher, I strive for discovery in various fields... architecture, animation, art, design, music, education, etc... Creativity fuels this unending journey along with my travel companions – collaborators, clients, students, teachers and supporters.

For more info visit www.sitesantos.com



Hi! I'm Henry...

DESIGNER . ANIMATOR . EDUCATOR

LISTENING ROOM: SOUNDRoom IN THE SKY

Design Concept

Audio Gear Concept Design:

- The Fog Horn Speaker System
- Nara Audio Cabinet
- Retrospective Turntable
- The Boheme Tube Amplifier

Software:

- Plasticity
- Vectorworks
- TwinMotion









FOG HORN Concept Design

This conceptual 3-way speaker system exemplifies the reimagined Bohemian aesthetic inspired by the Russian River. The Fog Horn Speaker System, part of The Boheme Line, features offset horns for midrange and high frequencies, complemented by a single



COVID-ERA OUTDOOR SPACES Event Layout Concept

Software:

- Vectorworks
- Enscape
- Photoshop
- Illustrator

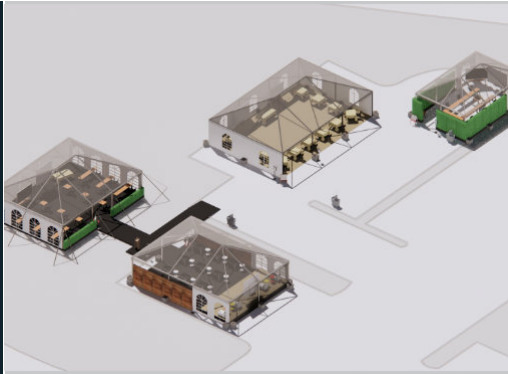

MOCHI MUNCH

MOCHI MUNCH Interior Visualization

Software:

- Vectorworks
- Affinity Photo
- Affinity Designer
- TwinMotion





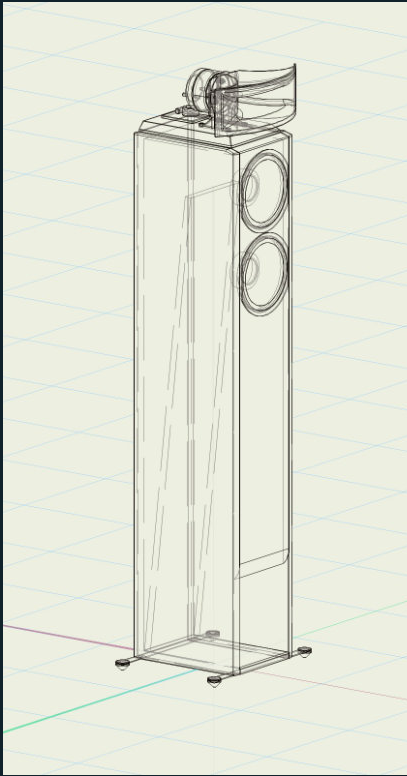



MUSIC ROOM Interior Concept

Audio Gear Concept Design:

- Voight Horn Speaker Towers
- The Leg Horn Speaker System
- Nara Audio Cabinet
- Retrospective Turntable
- Retrospective Tube Amplifier

Software:

- Plasticity
- Blender
- Vectorworks
- TwinMotion
- Affinity Designer

WEDDING TENT

Ceremony Concept

Software:

- Vectorworks
- Blender
- TwinMotion
- Photoshop





RETROSPECTIVE AUDIO LINE

Audio Gear Concept

Audio Gear Concept Design:

- Para-Para Speaker System
- Retrospective Turntable
- Retrospective Tube Amplifier
- Mid-Range & High Frequency Horn

Software:

- Plasticity
- Blender
- Vectorworks
- TwinMotion

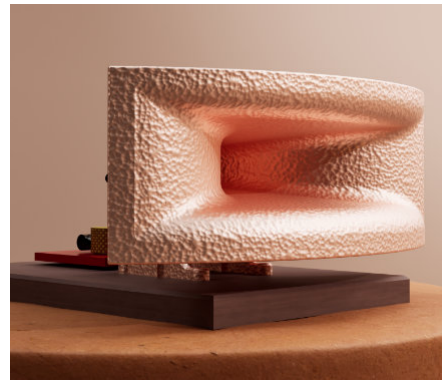



THE BOHEME TUBE AMP Design Concept Process

Audio Gear Concept Design:

- The Fog Horn Speaker System
- Nara Audio Cabinet
- Retrospective Turntable
- The Boheme Tube Amplifier

Software:

- Plasticity
- Blender
- Vectorworks
- TwinMotion

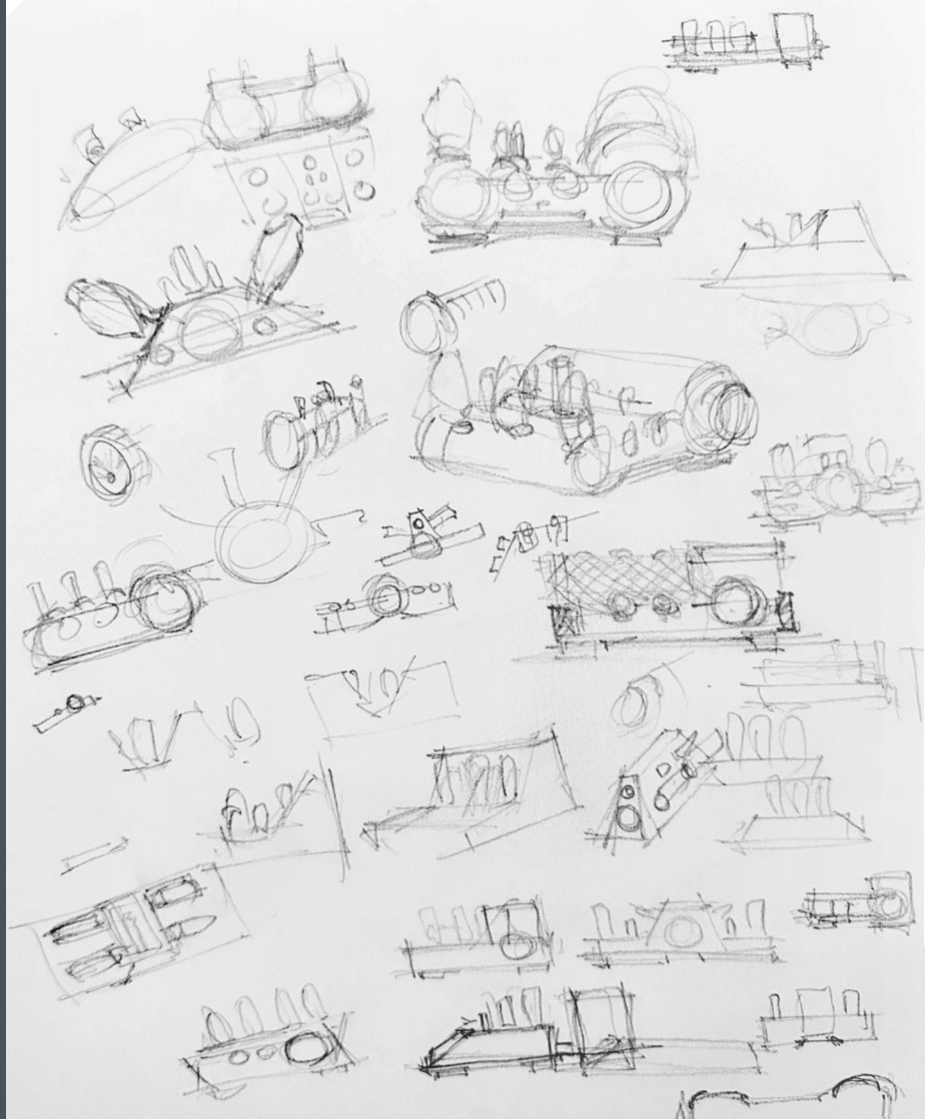

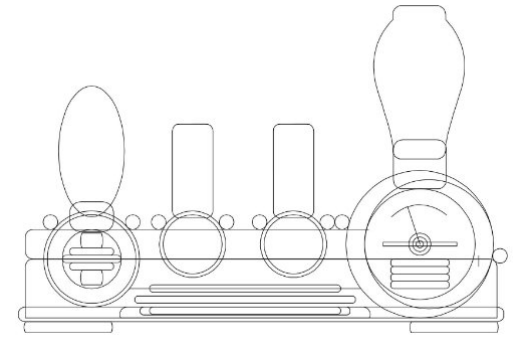
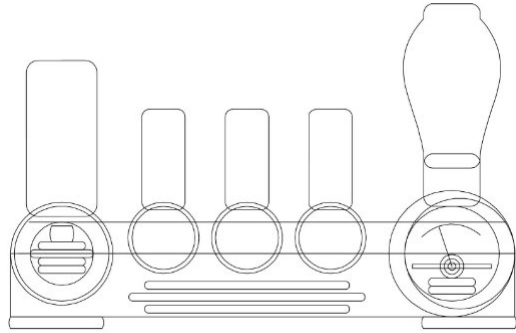

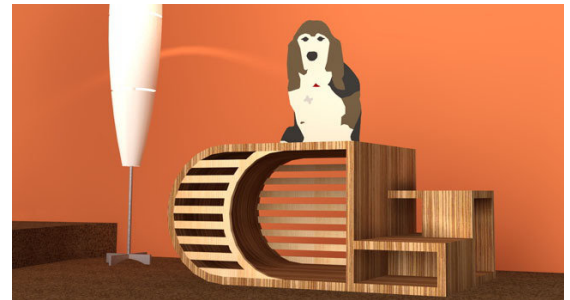
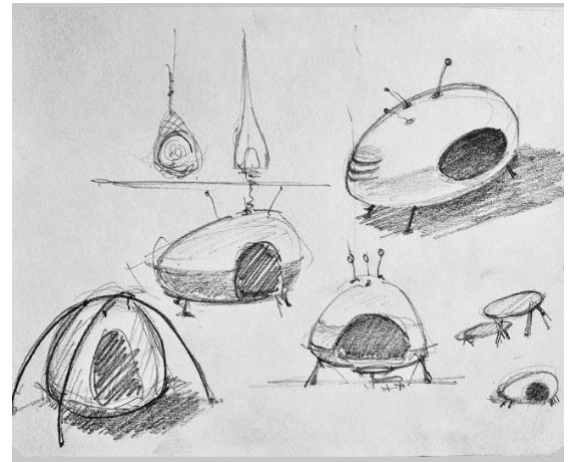
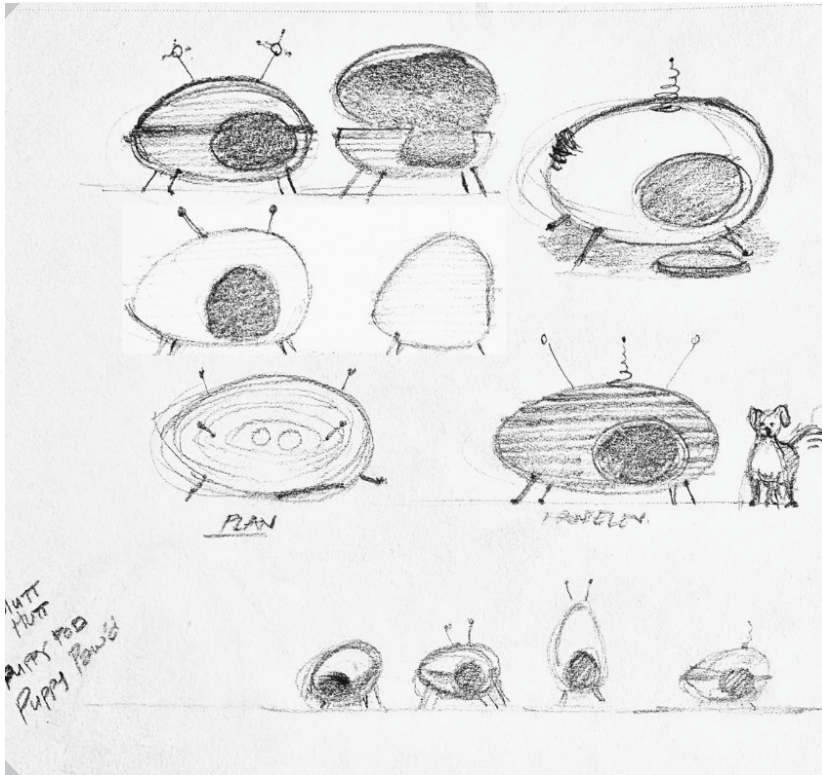

The Puppy Pod Design

A design competition at Lionakis called for a new approach to a canine housing. Build a better dog house...

My entry didn't win, but I am still very excited about my work. It had rave reviews and was the favorite of many of my peers. It lost out to a more easily built design. I still believe that this is quite buildable. I know Monti and Duchess would love to have one!

SOFTWARE:

- SketchUp
- MODO
- Photoshop

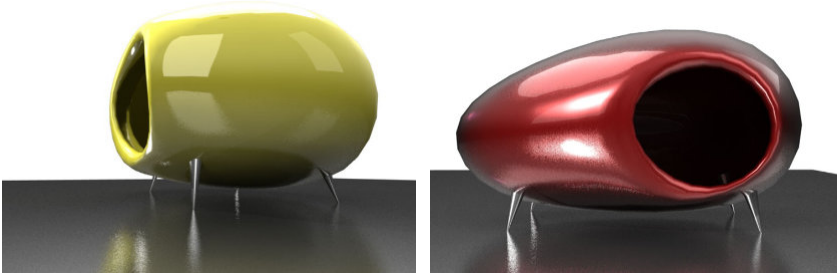
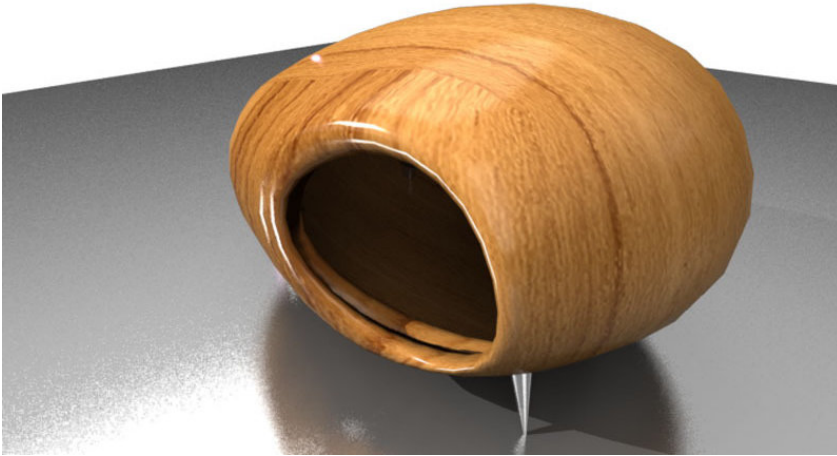

DESIGN DEVELOPMENT SKETCHES

Whether it's a structure, product, character or animation, I always start with sketches.

It's the quickest way to get an idea out of one's head. I also started my courses by encouraging my students to start sketching. The only bad sketch is the one you don't start!

These are just a sample of my sketching and drawing.

Now I need to go and sketch...

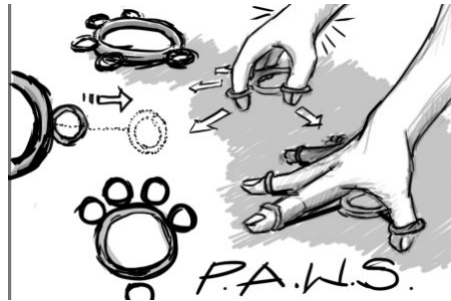





Henry Santos

Monte Rio CA USA

805.440.9220

henry@sitesantos.com

www.sitesantos.com